

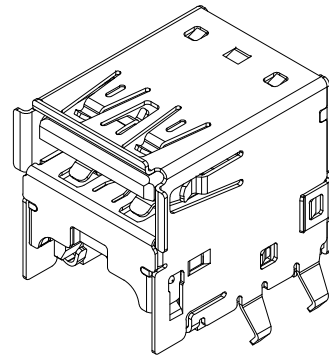

RoHS Compliant

REV.	ZONE	DESCRIPTION	DESIGN	DATE
B		NEW		

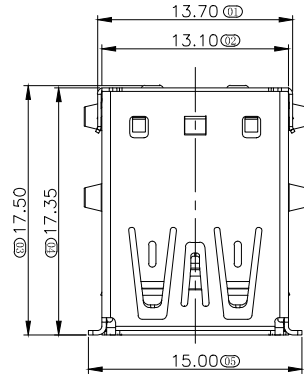

SPECIFICATIONS:

- 1.0 Electrical Performance:
 - 1.1 Contact current Rating:
 - 1.8 Amperes for VBUS and GND contacts.
 - 0.25 Amperes for all other contacts.
 - 1.2 Dielectric Withstanding Voltage:AC 100V(RMS).
 - 1.3 Insulation resistance:100M ohms Min.
 - 1.4 Contact Resistance:
 - 30m ohm Max for VBUS and GND contacts.
 - 50m ohm Max for all other contacts.
 - 1.5 Voltage Rating : 30 Vac (rms).
- 2.0 Mechanical Performance:
 - 2.1 Mating Force:35N Max.
 - 2.2 Unmating Force:10N Min 8N Min After Durability.
 - 2.3 Durability:5000 cycles.
- 3.0 Environmental Performance:
 - 3.1 Temperature Range:
 - 3.1.1 Operating Temperature:-55'to+85'.
 - 3.1.2 Storage Temperature:-20'to+60'.
 - 3.1.3 Salt Spray 24h Min.
- 4.0 MATERIAL:
 - 4.1 Housing:SEE TABLE,UL94-V0.
 - 4.2 Cover:SEE TABLE,UL94-V0.
 - 4.3 Contact:2.0 contacts C5191.
 - 3.0 contacts C2680.
 - 4.4 Shell:SUS304.
- 5.0 PLATING:
 - 5.1 Contact:Au Plated on contact area
 - Tin Plated on solder area
 - Nickel underplating over all.
 - 5.2 Shell: Tin Plated 50u" Min on solder area
 - Nickel 30u"Min underplating over all.

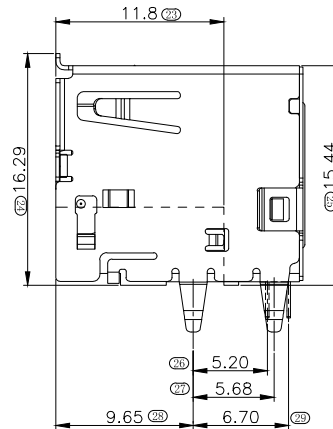
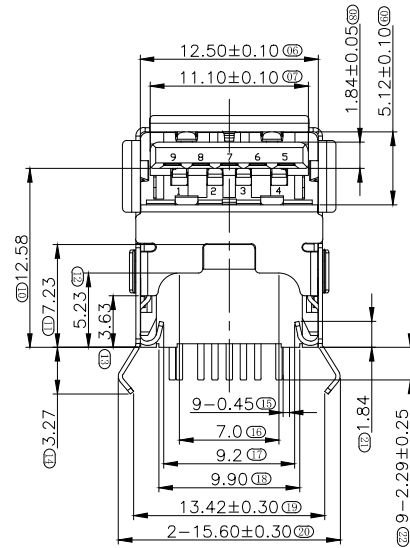

X. ±0.50	X.* ± 2°	UNITS	深圳市创粤科技有限公司		
.X ±0.30	.X* ± 1°	mm	TITLE:		
.XX ±0.10	.XX* ± 0.5°	MAT'L	USB 3.1 AF 架高 90度DIP [有卷边, 青蛙脚]		
.XXX ± 0.05		FINISH	APPD:	DWG NO.:	
THESE DRAWINGS AND SPECIFICATIONS ARE THE PROPERTY OF SHENZHEN CHUANGYUE TECHNOLOGY CO.,LTD. AND SHALL NOT BE REPRODUCED, COPIED OR USED IN ANY MANNER WITHOUT THE PRIOR WRITTEN CONSENT OF SHENZHEN CHUANGYUE TECHNOLOGY CO., LTD		Q'TY	CHKD:	SCALE SHEET REV.	
			DR:	1/1	1/1 A1